



**POWDER HANDLING
LIFTING EQUIPMENT**

BAGBOY ONE-WAY & UNIVERSAL

Big bag discharger for emptying big bags.

IBC's discharge system for big bags is available in several basic versions with a wide range of accessories, to make it adaptable for all customer needs. All machine systems are designed with high quality and accessibility. IBC has extensive experience in handling bulk products and offers custom-tailored bulk handling equipment after dischargers for transport, dosing, sieving and mixing of different types of products.

BAGBOY ONE-WAY

Big bag discharger for disposable bag.

BAGBOY UNIVERSAL

Big bag discharger for all bag types.

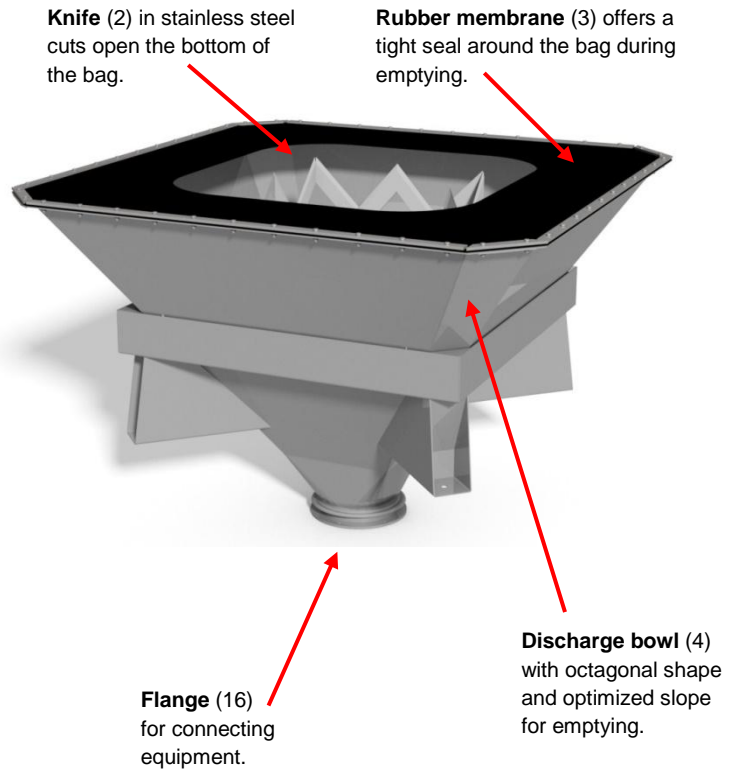

BAGBOY ONE-WAY type A

Floor stand (10a) with discharge bowl (4), rubber membrane (3), knife (2) and centering arms (1a) which fixes the bag.



BAGBOY ONE-WAY type B

Floor stand (10b) with discharge bowl (4), rubber membrane (3), knife (2), bag suspension stand (1b) and yoke for a fork lift or crane (18c).



BAGBOY ONE-WAY type C

Crane stand (10c) with discharge bowl (4), rubber membrane (3), knife (2), electrically powered chain telpther (17) and lifting yoke (18a).

IBC International Handling AB

Hamnvägen 1
S-311 32 Falkenberg, Sweden
Phone +46-346 569 10

Fax
E-mail
Home page

+46-346 569 18
sales@ibc-international.se
www.ibc-international.se



POWDER HANDLING
LIFTING EQUIPMENT

BAGBOY ONE-WAY & UNIVERSAL

Examples of accessories for BAGBOY ONE-WAY & UNIVERSAL



H-knife (2a), standard knife to cover most needs.



Pyramid knife (2b) for tough applications.



U-knife (2c) for bags with discharge spout.



Universal (5), model with a hatch in the discharge bowl for opening reusable bags, featuring a detachable knife system. Also available in Plexiglass.



Pneumatic vibrator (6a) ensures a steady product flow. Should be combined with a vibration damper (7) between the discharge bowl and stand.



Electric vibrator (6b) ensures a steady product flow. Should be combined with a vibration damper (7) between the discharge bowl and stand.



Butterfly valve, sliding valve or rotary valve (8) for controlling the product flow and partial discharge to downstream unit.



Fork lift pockets (9) for easily moving the discharger, and docking with various transportation systems.



Weighing system (12) available in numerous designs depending on the application requirements.

IBC International Handling AB

Hamnvägen 1
S-311 32 Falkenberg, Sweden
Phone +46-346 569 10

Fax
E-mail
Home page

+46-346 569 18
sales@ibc-international.se
www.ibc-international.se

Rev. 1



POWDER HANDLING
LIFTING EQUIPMENT

BAGBOY ONE-WAY & UNIVERSAL

Examples of accessories for BAGBOY ONE-WAY & UNIVERSAL



Lifting eyes (13) for lifting the discharger by crane.



Double rubber membranes (14) with intermediate dust extraction ramp for minimizing dusting.



Elevated discharge bowl (4a) for increased volume with **hatch for emptying small bags (19)**.



IBC standard bag yoke (18a).



IBC low-profile bag yoke (18b). Includes a counterweight and offers 150 mm negative lift height.



Iris valve (23) placed under the discharge bowl outlet. Used to easily cut the flow and enables reclosing of the bag.



Grate (24). Placed at the bottom of the discharge bowl to prevent the operator downstream equipment (e.g. screw).

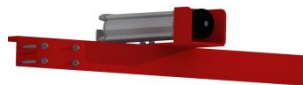

Pneumatic pushers (25) facilitate discharge of material from big bag. Mounted on the stand. Adjustable laterally and vertically.



Lump breaker is the perfect solution for crushing lumps in, for example, salt or talcum that have formed during material handling and which are soft enough to be crushed.

IBC International Handling AB

Hamnvägen 1
S-311 32 Falkenberg, Sweden
Phone +46-346 569 10

Fax
E-mail
Home page

+46-346 569 18
sales@ibc-international.se
www.ibc-international.se



POWDER HANDLING
LIFTING EQUIPMENT

BAGBOY ONE-WAY & UNIVERSAL

Applications



Double Bagboy One-Way type A with screw conveyor system.



Discharge bowl with Plexiglass hatch.

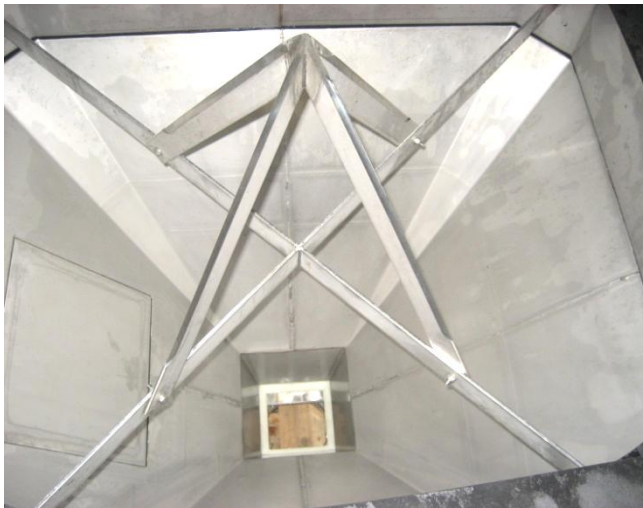

Pyramid knife.



H-knife.

IBC International Handling AB

Hamnvägen 1
S-311 32 Falkenberg, Sweden
Phone +46-346 569 10

Fax
E-mail
Home page

+46-346 569 18
sales@ibc-international.se
www.ibc-international.se



POWDER HANDLING
LIFTING EQUIPMENT

BAGBOY ONE-WAY & UNIVERSAL



Elevated discharge bowl.



Big bag discharger with screw conveyor for the offshore industry.

Examples of equipment that IBC offers for all discharge systems

- Screw conveyor
- Vacuum conveyor
- Pressure conveyor
- Vibration feeder
- Filters
- Rotary valve

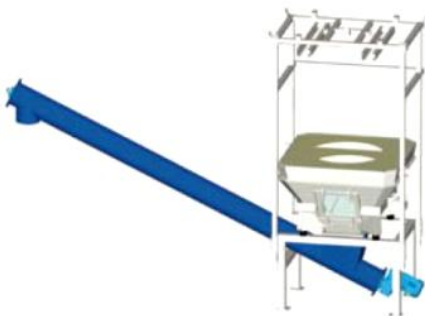

Screw conveyor

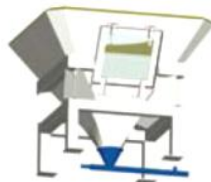

Vacuum conveyor



Pressure conveyor



Filter and rotary valve

IBC International Handling AB

Hamnvägen 1
S-311 32 Falkenberg, Sweden
Phone +46-346 569 10

Fax
E-mail
Home page

+46-346 569 18
sales@ibc-international.se
www.ibc-international.se